

# IS31FL3248 Performance 48 Channel Serial-Shift LED Driver



LED lighting has become an indispensable part of our lives. From automobiles to appliances and signage displays, LEDs are everywhere. To deliver the right lighting experience, LEDs require precise and consistent brightness control, color rendering, small thermal footprint and minimal noise. This is where the IS31FL3248 LED driver comes in.

The IS31FL3248 uses proprietary programmable algorithms to minimize audible noise that can result from the LED's PWM causing the MLCC decoupling capacitors to expand and contract. With its 16-bit, 8+8-bit dithering, 8+4-bit dithering, and 8-bit PWM mode, the IS31FL3248 is capable of PWM modulating the LED brightness with 256/4096/65536 steps. This allows for a wide range of lighting patterns, such as the popular breathing effect. The IS31FL3248 also has real-time LED open and short detection, and over-temperature protection.

The IS31FL3248 is a 48-channel constant current LED driver that offers an array of features for high performance LED designs. Each channel has 16-bit PWM brightness control, and 64 steps of constant-current scaling [SL] to adjust the brightness deviation between channels. The Global Current Control [GCC] can adjust the brightness deviation between the R, G, and B color groups. The eight-step maximum current band control [CB] selects the maximum output current range for all channels. The IS31FL3248 also has a software shutdown mode that puts the device to sleep, reducing power consumption while retaining all register values. All the registers, including SL, GCC, CB, and others, can be programmed via a high-speed serial-shift (up to 33MHz) or SPI (up to 33MHz) serial interface port,

Figure 1. A serial shift architecture enables a single microcontroller [MCU] to control many LEDs using minimal GPIO pins. The MCU outputs a serial data stream to the serial input [DI] of the IS31FL3248 which is clocked in via the input clock [SCLK]. Once the 48-bit shift register is loaded, the latch signal [LAT] applies the 48 bits of serial data to the integrated LED drivers that sink the LED current. The serial data stream is partitioned between PWM and current adjustment data.

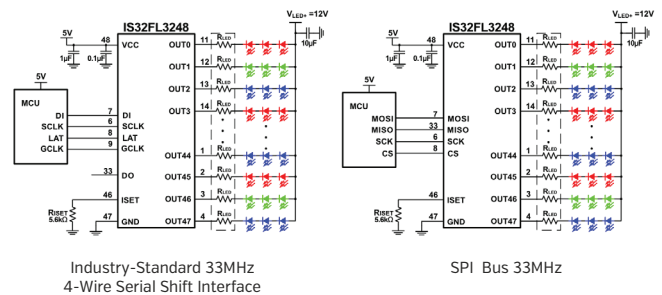

Figure 1: IS31FL3248 Serial Bus Options

The IS31FL3248's OUTx channels are designed for a high voltage input and are capable of sinking 33mA [typ] whether it be one LED or a string of 3 LEDs as shown above. The only limitation on the string size is the number of LEDs must satisfy the following equation:

$$V_{OUTx} > V_{LED+} - V_F * N - V_R$$

Where  $V_{LED+}$  is the string anode voltage (upto 16V),  $V_F$  is the LED's forward voltage, N is the number of LEDs in the string, and  $V_R$  is the voltage  $[I * R]$  of the series resistor (if used)

Note:  $V_{OUTx} = V_{HR}$ , both refer to the voltage drop on the OUTx channel.  $V_{HR}$  must always be  $> 0.4V$  to maintain accurate current regulation

**STACKED LEDs**

LEDs can be stacked in a string to take advantage of the IS31FL3248's high voltage OUTx capability. By stacking the same color LEDs in a string it is possible to increase the light output by a factor of the number of stacked LEDs. In the example above, the light output is 3x of a single LED for the same channel current.

**DRIVING AN ARRAY OF LEDs**

An added benefit of using serial interface LED drivers is they can be used to create matrix LED drivers that help reduce PCB size and BOM costs in designs that use many LEDs. The serial IN and serial OUT interface enables the use of less expensive microcontrollers for cascading multiple IS31FL3248s as shown in the Figure 2 below. The serial OUT at the end of the cascade can be routed to the microcontroller as a status input to verify data transfer integrity. The external FETs on SW0~1 are turned ON/OFF in a sequential pattern [Figure 4] and at a fast rate so flicker is not visible as one VLEDx row turns OFF and the next VLEDx row turns ON. The LED's common anodes are tied together to their respective horizontal VLEDx line. This arrangement means current is supplied from only one VLEDx at a time.

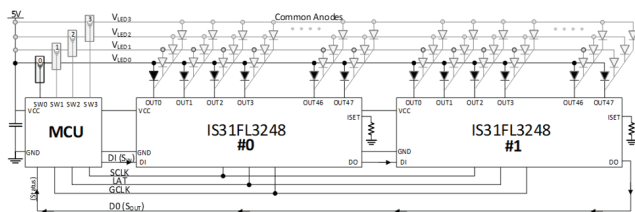

Figure 2. 4x96 Matrix Array Using 4 FETs and Two IS31FL3248 Devices

Lumissil makes a family of dedicated matrix LED drivers such as the IS31FL3748 with integrated FET switches that support high voltage OUTx channels perfect for LED stacking. Like the IS31FL3248, the IS31FL3748 also supports a serial interface for cascading multiple devices.

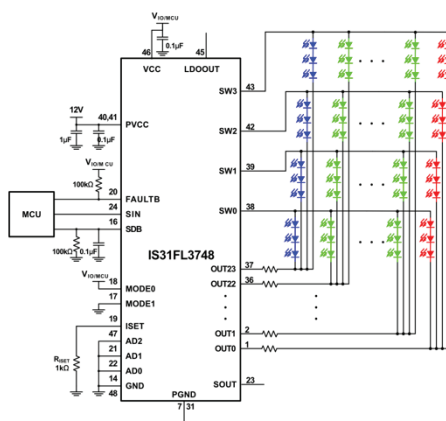

Figure 3. IS31FL3748 Fully Integrated Matrix LED Driver circuit

**ADVANTAGES OF EXTERNAL FET DESIGN**

**Low I<sup>2</sup>R thermal** - A matrix design as shown in Figure 2. uses external FETs while an integrated solution as in Figure 3 has the FETs as part of the silicon die. Having the FETs designed on the die limits the FET switch performance due to substrate design parameters. Using external FETs expands the options when selecting a FET; it is possible to purchase FETs with extremely low drain-source ON resistance (R<sub>DS(ON)</sub>); not possible if the FETs are integrated. A low R<sub>DS(ON)</sub> means lower I<sup>2</sup>R thermal dissipation.

**Low Package Thermal** - External FETs have lower I<sup>2</sup>R thermal dissipation and do not contribute to device thermal buildup since they are physically outside of the package. An integrated solution has the FETs with higher R<sub>DS(ON)</sub> fabricated on the LED driver die which will contribute to a total package thermal build up.

**Lower BOM Cost** - As shown in Figure 2, it is possible to design a large matrix array using two or more cascading IS31FL3248 devices while using only one set of FET switches and one MCU. A single IS31FL3248 device supports 48 LED channels while the IS31FL3748 supports only half; 24 channels

**ADVANTAGES OF INTEGRATED DESIGN**

**Parasitic Capacitance** - LED arrays tend to display a 'ghosting' effect where stray parasitic capacitance in the array will discharge through a random LED causing it to dimly turn on. Lumissil's integrated matrix drivers are designed with 'De-Ghosting' technology to actively discharge stray capacitance and avoid this. An integrated matrix device will include parasitic discharge [and other enhancements] during the scan timing, something that is difficult to implement with a discrete design, Figure 4. An integrated matrix driver solution has other performance features such as clock spread spectrum, LED open/short detection, etc, not possible in a discrete solution.

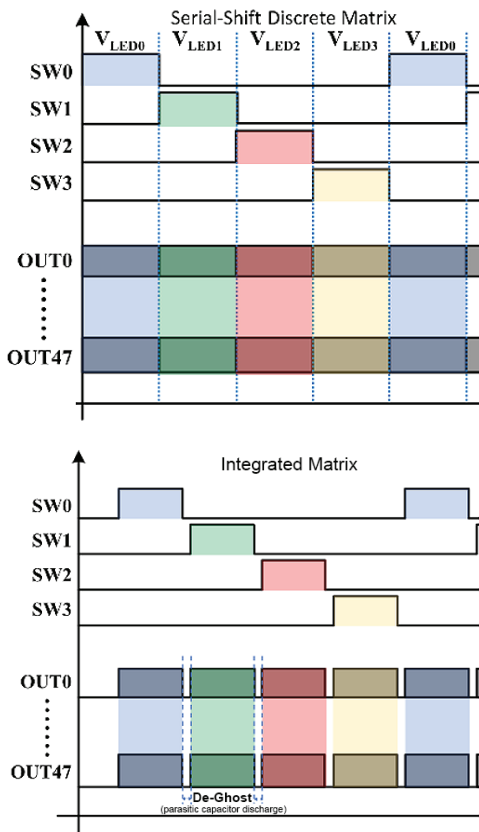

Figure 4 Matrix Scan Timing Differences [see Figure 2]

**IN SUMMARY**

LED lighting can be found in a wide range of applications; choosing the right LED driver can be complicated as there are many parameters to consider. Fortunately, Lumissil has a wide selection of LED drivers that fit a majority of the applications. The IS31F3248 and IS32FL3248 are the latest examples of LED drivers from Lumissil. Contact [marketing@lumissil.com](mailto:marketing@lumissil.com) for more information.

Choosing to design a discrete matrix driver instead of using an integrated version should be decided after careful consideration of the features and benefits for both approaches.

**APPLICATIONS**

**Consumer/Industrial** - The IS31FL3248 is an ideal LED driver for applications with many LEDs to be controlled by a simple serial shift bus architecture. These include banks of 7-segment displays and single indicators as well as arrays of LEDs that form grids or panels as shown in Figure 5. These segmented displays are typically found on control panels for appliances or industrial applications. Simple signage displays composed of large LED dot arrays are also perfect applications for the IS31FL3248.

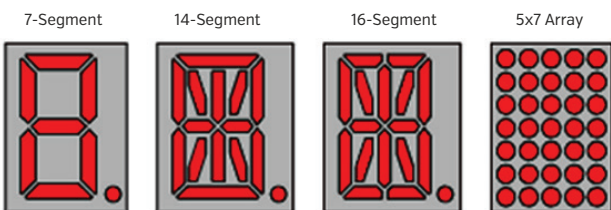

Figure 5 Types of Segment Displays